

Any constructive recommendations / comments on safety systems, required devices and layout appreciated - Cookie

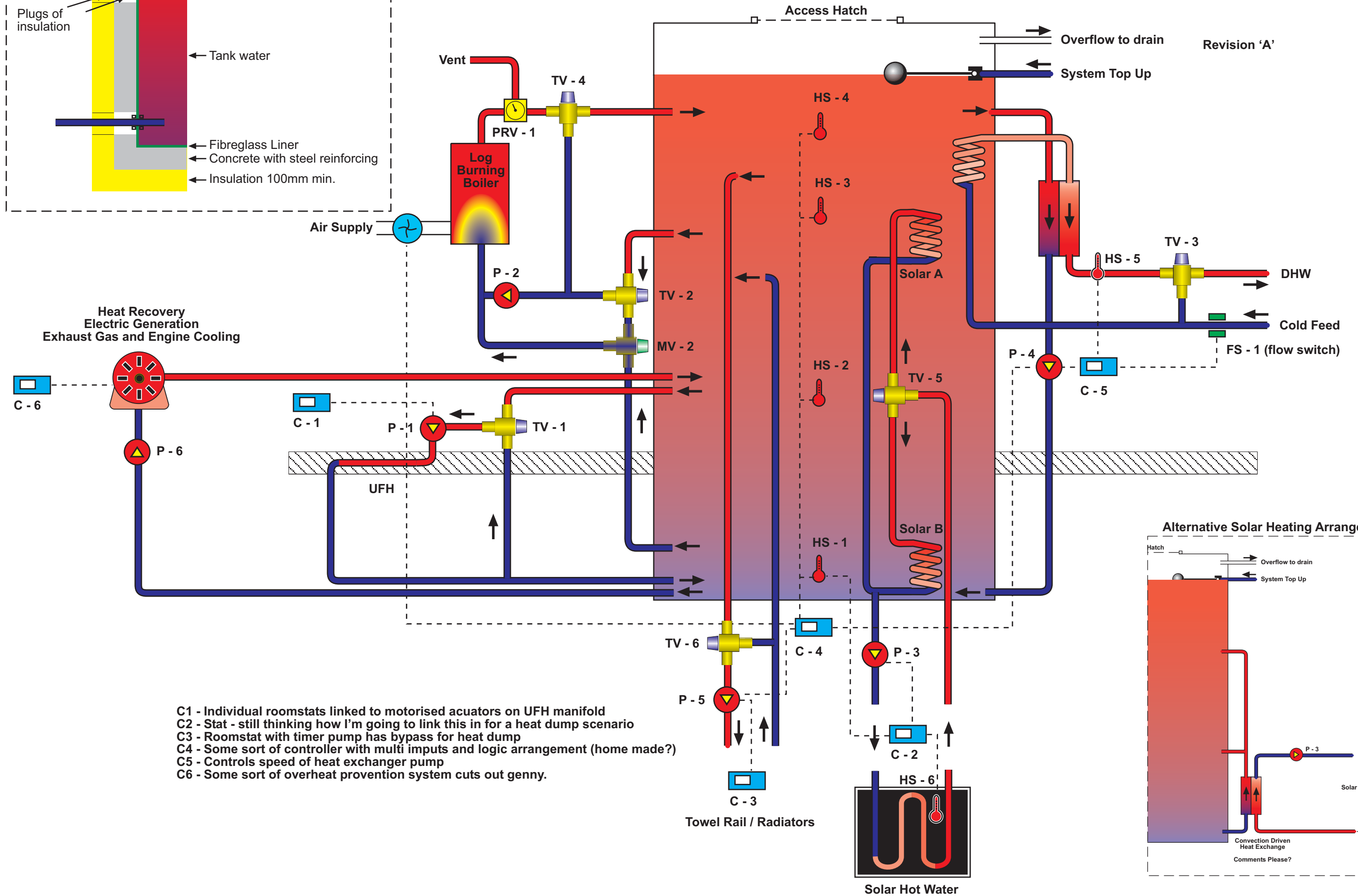

- C1 - Individual roomstats linked to motorised actuators on UFH manifold
- C2 - Stat - still thinking how I'm going to link this in for a heat dump scenario
- C3 - Roomstat with timer pump has bypass for heat dump
- C4 - Some sort of controller with multi inputs and logic arrangement (home made?)
- C5 - Controls speed of heat exchanger pump
- C6 - Some sort of overhear prevention system cuts out genny.

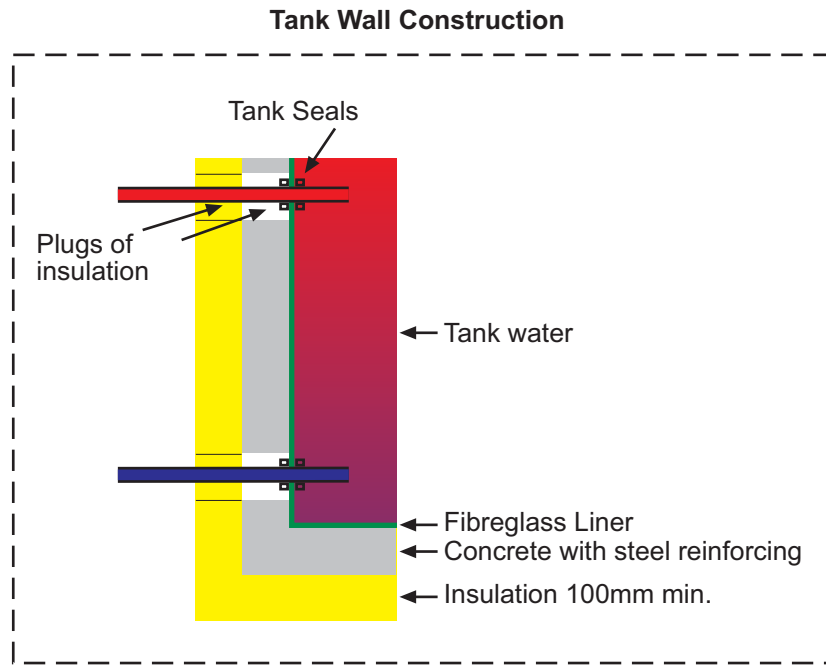